

Dell Edge Gateway

5000 Series

Installation and Operation Manual

Computer Model: Dell Edge Gateway 5000\5100
Regulatory Model: N01G\N02G
Regulatory Type: N01G001\N02G001



Notes, cautions, and warnings



NOTE: A NOTE indicates important information that helps you make better use of your computer.



CAUTION: A CAUTION indicates either potential damage to hardware or loss of data and tells you how to avoid the problem.



WARNING: A WARNING indicates a potential for property damage, personal injury, or death.

© 2016 Dell Inc. All rights reserved. This product is protected by U.S. and international copyright and intellectual property laws. Dell and the Dell logo are trademarks of Dell Inc. in the United States and/or other jurisdictions. All other marks and names mentioned herein may be trademarks of their respective companies.

2016 - 01

Rev. A001

Contents

Overview	5
System Features	6
System LEDs	8
DIP switches	9
Setting up your Dell Edge Gateway	10
Professional installation instructions	11
Instructions d'installation professionnelles	11
Federal Communication Commission Interference Statement	12
Industry Canada Statement	13
Powering on the system	15
Mounting the Dell Edge Gateway on the wall	16
Mounting the Dell Edge Gateway on a DIN rail	19
Inserting a micro-SIM card and activating your mobile broadband	21
Removing the micro-SIM card	23
Setting up your operating system	25
Windows 10 Enterprise	25
Ubuntu Snappy	25
Wind River Linux	25
Specifications	26
I/O Module Overview	29
Features	30
Setting up the I/O Module	31
Specifications	36

Power Module Overview.....	40
Features.....	41
Setting up the Power Module.....	42
Power module — Connecting a battery.....	47
Specifications.....	49
Enclosure Overview.....	51
Features.....	51
Setting up the Enclosure.....	53
Specifications.....	60
Setting up the ZigBee Dongle	62
Contacting Dell.....	64

Overview

The Dell Edge Gateway 5000/5100 series allows you to connect (wired or wireless) to network enabled devices and manage them remotely in your existing network ecosystem. The system can be either mounted on the wall using the Dell approved wall mount kit or mounted into your existing rack infrastructure using the DIN-rail mounting bracket. The system is running on Windows 10 Enterprise, Ubuntu Snappy, and Wind River Linux operating systems. As part of a complete interoperable building automation system, Edge Gateway provides precise monitoring and control of connected points. I/O expansion module provide the Edge Gateway with additional inputs and output module. The power expansion module provide the Edge Gateway with power redundancy options by allowing you to connect a 24V AC/DC, a 19.5V DC, and a battery backup simultaneously.

If the Edge Gateway is setup as a web server, it offers the capability for configuration from a web browser. Configure I/Os, set-up objects, and monitor present values via a browser.

System Features

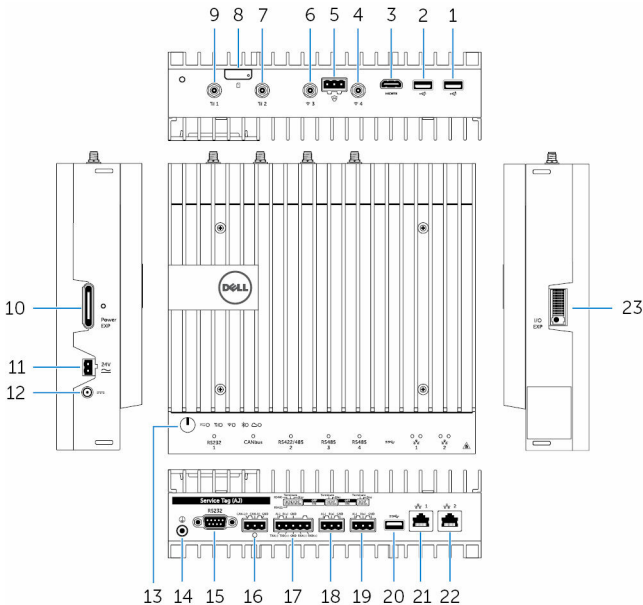

Feature

- | | | |
|----|--|--|
| 1. | USB 2.0 port | For USB 2.0 devices |
| 2. | USB 2.0 port | For USB 2.0 devices |
| 3. | HDMI port | Connect a Monitor or another HDMI-in enabled device. Provides video and audio output. |
| 4. | Wi-Fi antenna port (port four) | Connect an antenna to increase the range and strength of the Wi-Fi signals. |
| 5. | Intrusion detection connector | Connect a TPB based security device to detect any intrusion into the system. |
| 6. | Wireless antenna port (port three) | Connect an antenna to increase the range and strength of the Wi-Fi signals. |
| 7. | Mobile broadband antenna port (port two) | Connect an antenna to increase the range and strength of the mobile broadband signals. |

Feature

8.	Micro-SIM card slot	Insert a micro-SIM card to connect to a mobile broadband network.
9.	Mobile broadband antenna port (port one)	Connect an antenna to increase the range and strength of the mobile broadband signals.
10.	Power module expansion port	Connect an external power module for increased power options.
11.	+24V AC/DC power Phoenix connector	Connect a +24V AC/DC power connector to provide power to your system
12.	+19.5 VDC power adapter port	Connect a +19.5 VDC power adapter connector to provide power to your system
13.	Power button	Press and hold for 2 seconds to turn on the system if it is turned off.
14.	Earth ground	Connect the grounding cable to the system
15.	Serial port	Connect to a serial port enabled device like printers and so on.
16.	CANbus port	Connect to a CANbus port enabled device or dongles.
17.	RS422/485 port	Connect a RS422/485 device.
18.	RS485 port	Connect a RS422 device.
19.	RS485 port	Connect a RS485 device.
20.	USB 3.0 port	For USB 3.0 devices
21.	Network port	Connect an Ethernet (RJ45) cable from a router or a broadband modem for network or internet access.
22.	Network port	Connect an Ethernet (RJ45) cable from a router or a broadband modem for network or internet access.
23.	I/O expansion port	Connect an external expansion module for additional I/O ports.

System LEDs

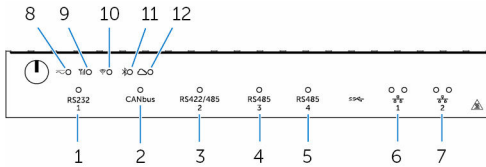

Feature

- | | | |
|-----|-----------------------------|--|
| 1. | Serial port status LED | Provide the status of the serial port connection. |
| 2. | CANbus port status LED | Provide the status of the CANbus port connection. |
| 3. | RS422/485 port status LED | Provide the status of the RS422/485 port connections. |
| 4. | RS485 port status LED | Provide the status of the RS485 port connections. |
| 5. | RS485 port status LED | Provide the status of the RS485 port connections. |
| 6. | Network status LED | Indicates the connectivity status and network activity. |
| 7. | Network status LED | Indicates the connectivity status and network activity. |
| 8. | Power status LED | Indicates the power-state of the system. |
| 9. | Mobile broadband status LED | Indicates the mobile broadband status and network activity. |
| 10. | Wireless status LED | Indicates the wireless connectivity status and network activity. |
| 11. | Bluetooth status LED | Indicates the bluetooth status and activity. |
| 12. | Cloud connection status LED | Indicates the cloud connection status. |



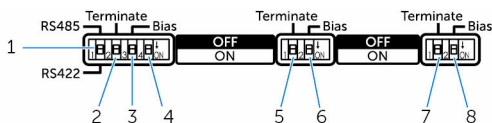





DIP switches







Feature

- | | | |
|----|---------------------------------------|--|
| 1. | RS422/RS485 port toggle switch | Toggle between RS422 or RS485 standard |
| 2. | RS422/RS485 port resistor switch | Enable/disable the differential termination resistor |
| 3. | RS422/RS485 port bias resistor switch | Enable/disable the bias resistor for the RS422/RS485 port |
| 4. | RS422/RS485 port diagnostic switch | Enable or disable the RS422/RS485 port |
| 5. | RS485 port resistor switch | Enable/disable the differential termination resistor for RS485 |
| 6. | RS485 port bias resistor switch | Enable/disable the bias resistor for the RS485 port |
| 7. | RS485 port resistor switch | Enable/disable the differential termination resistor for RS485 |
| 8. | RS485 port bias resistor switch | Enable/disable the bias resistor for the RS485 port |

Setting up your Dell Edge Gateway

-  **WARNING:** Before you begin any of the procedures in this section, read the safety information that shipped with your system. For additional best practices information, go to www.dell.com/regulatory_compliance.
-  **WARNING:** When installing the Gateway, the responsible party or integrator shall use the AC Adapter provided with the Dell Edge Gateway, or connect to a 24Vac or 24Vdc power source already present as part of the clients installation.
-  **WARNING:** The Dell AC Adapter (full-wave rectified and have no built-in isolation transformer) is acceptable for use up to ambient temperature of 40°C and is a limited power source, SELV/Limited Energy Circuit, Class 2 power source. If ambient temperature of the installation exceeds 40 °C then use the 24Vac or 24Vdc power available as part of the installation.
-  **WARNING:** Always make sure that the available power source matches the required input power of the Dell Edge Gateway, check the input power markings next to power connector(s) before making connections. The 24 V power source must be compliant with local Electrical Codes and Regulations.
-  **WARNING:** To ensure the protection provided by Dell Edge Gateway is not impaired, do not use or install the system in any manner other than that which is specified in this manual.
-  **WARNING:** Use cable appropriate for the load currents: 3-core cable rated 5 A at 90 °C (194 °F) minimum, which conform to either IEC 60227 or IEC 60245. The system accepts cables from 0.8 to 2.5 mm (18 to 14 AWG).
-  **WARNING:** The symbol  indicates hot surface or adjacent hot surface that can obtain temperature during normal use that can cause a burn. Allow equipment to cool off or use protective gloves when handling to reduce risk of a burn.
-  **WARNING:** If a battery is included as part of System/Network, battery must be installed with appropriate enclosure in accordance with local Fire and Electrical Codes and Laws.

-  **WARNING:** Before installing that all of three power inputs (Terminal Block/Power Jack/Battery Input) in power module shall be protected by the 20 A fuses or circuit-breakers(over current protection device) in front of this system.
-  **WARNING:** The system is for installation in a suitable industrial enclosure (provides electrical, mechanical and fire hazard protection).
-  **WARNING:** The core module only can be wall mounted (without the need for an additional enclosure)
-  **WARNING:** Only Sealed Lead Acid (SLA) battery rated 50Ah (or less) shall be used

Professional installation instructions

Installation personnel

This product is designed for specific applications and needs to be installed by qualified personnel with RF and regulatory related knowledge. The general user shall not attempt to install or change the setting.

Installation location

The product shall be installed at a location where the radiating antenna is kept 20 cm from nearby persons in its normal operation condition in order to meet regulatory RF exposure requirements.

External antenna

Use only the antenna(s) which have been approved by the applicant. Non-approved antenna(s) may produce unwanted spurious or excessive RF transmitting power which may lead to a violation of FCC/IC limits and is prohibited.

Installation procedure

Please refer to user's manual for the detail.

-  **WARNING:** Please carefully select the installation position and make sure that the final output power does not exceed the limits set forth in relevant rules. The violation of these rules could possibly lead to serious federal penalties.

Instructions d'installation professionnelles

Le personnel d'installation

Ce produit est conçu pour des applications spécifiques et doit être installé par un personnel qualifié avec RF et connaissances connexes réglementaire. L'utilisateur ne doit pas tenter générale d'installer ou de modifier le réglage.

Lieu d'installation

Le produit doit être installé à un endroit où l'antenne de rayonnement est maintenue à 20 cm de personnes à proximité dans son état de fonctionnement normal, afin de répondre aux exigences réglementaires d'exposition aux radiofréquences.

Antenne externe

Utilisez uniquement l'antenne(s) qui ont été approuvés par le demandeur. Antenne (s) peuvent produire de l'énergie RF parasite indésirable ou excessive transmission qui peut conduire à une violation des normes de la FCC / IC est interdite et non-approuvé.

Procédure d'installation

ATTENTION: S'il vous plaît choisir avec soin la position d'installation et assurez-vous que la puissance de sortie final ne dépasse pas les limites fixées dans les règles pertinentes. La violation de ces règles pourrait conduire à des sanctions fédérales graves.

Federal Communication Commission Interference Statement

This device complies with Part 15 of the FCC Rules. Operation is subject to the following two conditions: (1) This device may not cause harmful interference, and (2) this device must accept any interference received, including interference that may cause undesired operation.

This equipment has been tested and found to comply with the limits for a Class B digital device, pursuant to Part 15 of the FCC Rules. These limits are designed to provide reasonable protection against harmful interference in a residential installation. This equipment generates, uses and can radiate radio frequency energy and, if not installed and used in accordance with the instructions, may cause harmful interference to radio communications. However, there is no guarantee that interference will not occur in a particular installation. If this equipment does cause harmful interference to radio or television reception, which can be determined by turning the equipment off and on, the user is encouraged to try to correct the interference by one of the following measures:

- Reorient or relocate the receiving antenna.
- Increase the separation between the equipment and receiver.

- Connect the equipment into an outlet on a circuit different from that to which the receiver is connected.
- Consult the dealer or an experienced radio/TV technician for help.

FCC Caution:

- Any changes or modifications not expressly approved by the party responsible for compliance could void the user's authority to operate this equipment.
- This transmitter must not be co-located or operating in conjunction with any other antenna or transmitter.

Radiation Exposure Statement:

This equipment complies with FCC radiation exposure limits set forth for an uncontrolled environment. This equipment should be installed and operated with minimum distance 20cm between the radiator & your body.

 **NOTE:** Note: The country code selection is for non-US model only and is not available to all US model. Per FCC regulation, all WiFi product marketed in US must fixed to US operation channels only.

Industry Canada Statement

This device complies with Industry Canada license-exempt RSS standard(s). Operation is subject to the following two conditions:

- 1 this device may not cause interference, and
- 2 this device must accept any interference, including interference that may cause undesired operation of the device.

Le présent appareil est conforme aux CNR d'Industrie Canada applicables aux appareils radio exempts de licence. L'exploitation est autorisée aux deux conditions suivantes:

- 1 l'appareil ne doit pas produire de brouillage, et
- 2 l'utilisateur de l'appareil doit accepter tout brouillage radioélectrique subi, même si le brouillage est susceptible d'en compromettre le fonctionnement.

This Class B digital apparatus complies with Canadian ICES-003.

Cet appareil numérique de la classe B est conforme à la norme NMB-003 du Canada.

This device complies with RSS-310 of Industry Canada. Operation is subject to the condition that this device does not cause harmful interference.

Cet appareil est conforme à la norme RSS-310 d'Industrie Canada. L'opération est soumise à la condition que cet appareil ne provoque aucune interférence nuisible.

This device and its antenna(s) must not be co-located or operating in conjunction with any other antenna or transmitter, except tested built-in radios.

Cet appareil et son antenne ne doivent pas être situés ou fonctionner en conjonction avec une autre antenne ou un autre émetteur, exception faites des radios intégrées qui ont été testées.

The County Code Selection feature is disabled for products marketed in the US/Canada.

La fonction de sélection de l'indicatif du pays est désactivée pour les produits commercialisés aux États-Unis et au Canada.

Radiation Exposure Statement: This equipment complies with IC radiation exposure limits set forth for an uncontrolled environment. This equipment should be installed and operated with minimum distance 20cm between the radiator & your body.

Déclaration d'exposition aux radiations: Cet équipement est conforme aux limites d'exposition aux rayonnements IC établies pour un environnement non contrôlé. Cet équipement doit être installé et utilisé avec un minimum de 20 cm de distance entre la source de rayonnement et votre corps.

Caution:

- 1 The device for operation in the band 5150-5250 MHz is only for indoor use to reduce the potential for harmful interference to co-channel mobile satellite systems;
- 2 The maximum antenna gain permitted for devices in the bands 5250-5350 MHz and 5470-5725 MHz shall comply with the eirp limit; and
- 3 The maximum antenna gain permitted for devices in the band 5725-5825 MHz shall comply with the eirp limits specified for point-to-point and non point-to-point operation as appropriate.
- 4 The worst-case tilt angle(s) necessary to remain compliant with the eirp elevation mask requirement set forth in Section 6.2.2(3) shall be clearly indicated.
- 5 Users should also be advised that high-power radars are allocated as primary users (i.e. priority users) of the bands 5250-5350 MHz and 5650-5850 MHz and that these radars could cause interference and/or damage to LE-LAN devices.

Avertissement:

- 1 Les dispositifs fonctionnant dans la bande 5150-5250 MHz sont réservés uniquement pour une utilisation à l'intérieur afin de réduire les risques de brouillage préjudiciable aux systèmes de satellites mobiles utilisant les mêmes canaux;
- 2 Le gain maximal d'antenne permis pour les dispositifs utilisant les bandes 5250-5350 MHz et 5470-5725 MHz doit se conformer à la limite de p.i.r.e.;
- 3 Le gain maximal d'antenne permis (pour les dispositifs utilisant la bande 5725-5825 MHz) doit se conformer à la limite de p.i.r.e. spécifiée pour l'exploitation point à point et non point à point, selon le cas.
- 4 Les pires angles d'inclinaison nécessaires pour rester conforme à l'exigence de la p.i.r.e. applicable au masque d'élévation, et énoncée à la section 6.2.2 3), doivent être clairement indiqués.
- 5 De plus, les utilisateurs devraient aussi être avisés que les utilisateurs de radars de haute puissance sont désignés utilisateurs principaux (c.-à-d., qu'ils ont la priorité) pour les bandes 5250-5350 MHz et 5650-5850 MHz et que ces radars pourraient causer du brouillage et/ou des dommages aux dispositifs LAN-EL.

Powering on the system

- 1 Install the Dell Edge Gateway on the wall mount using the Dell approved [wall mounting kit](#).
or
Install the Dell Edge Gateway on the rack infrastructure using the Dell approved [DIN-rail mounting brackets](#).
- 2 Connect the network cable.
or
Install the wireless antenna to enable the wireless connections
- 3 Connect a display to the system.
- 4 Connect a keyboard and mouse if accessing the system directly.
- 5 Connect a SELV/limited energy circuit power source to the Dell Edge Gateway.
- 6 Connect a grounding cable to the system if required.
- 7 Press the power button to power on the computer.
- 8 If setting up the system for the first time, complete the operating system setup.



NOTE: The Dell Edge Gateway is shipped with either Windows 10 Enterprise, Ubuntu Snappy, or Wind River Linux operating systems.

- 9 Connect and configure to devices using the RS422/RS485 ports.

 **NOTE:** Turn on the corresponding dip switches to enable the corresponding RS422/R485 ports.

Mounting the Dell Edge Gateway on the wall

You can mount the Dell Edge Gateway on a wall by using mounting brackets. The brackets secure the Dell Edge Gateway to the wall.

- 1 Secure the two mounting brackets to the rear of the Dell Edge Gateway by using four screws.

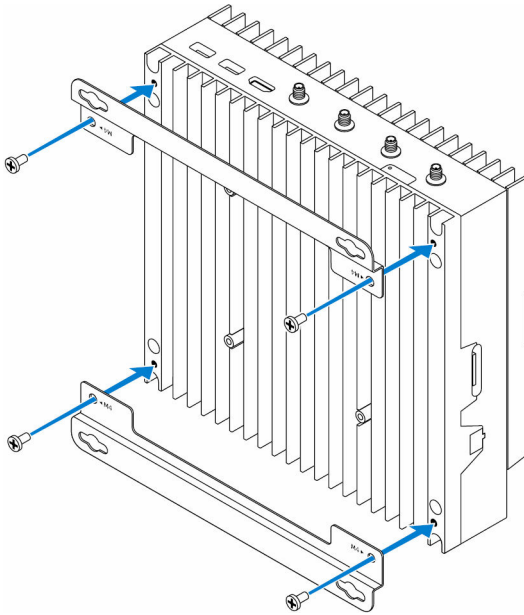

- 2 Drill four holes in the wall that correspond to the holes in the mounting bracket, then place the Dell Edge Gateway against the wall and align the holes in the mounting brackets with the holes in the wall.

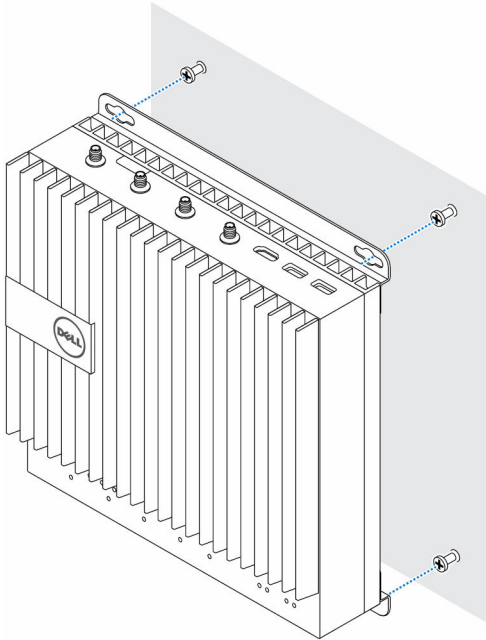

- 3 Tighten the screws to secure the Dell Edge Gateway to the wall.

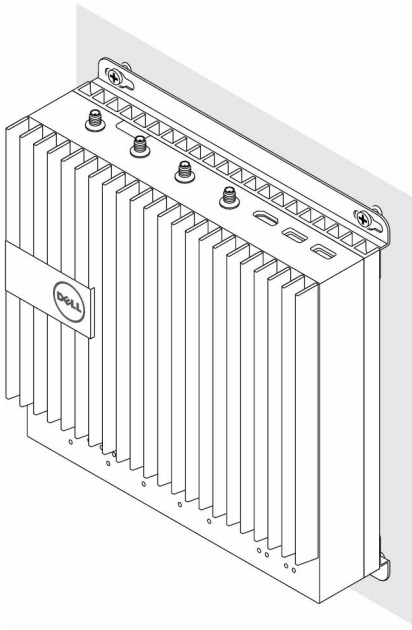

Mounting the Dell Edge Gateway on a DIN rail

The Dell Edge Gateway can be mounted on a DIN rail. The DIN rail bracket mounts to the back of the Dell Edge Gateway.

- 1 Align the screw holes on the DIN rail mount to the back of the Dell Edge Gateway, place the screws on the DIN rail mount and secure it to the Dell Edge Gateway

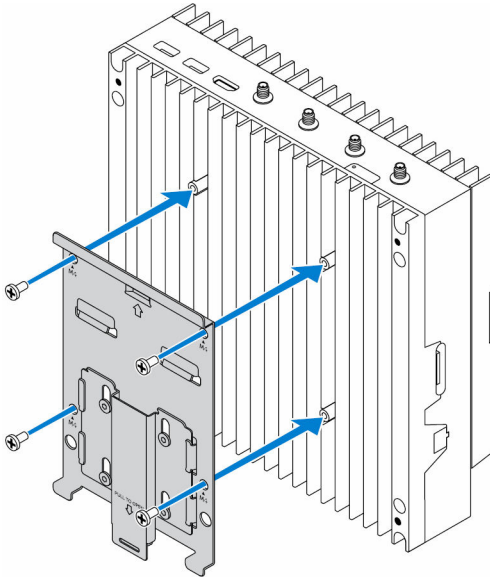

- 2** Pull down on the tab to release the latch on the DIN rail mount.

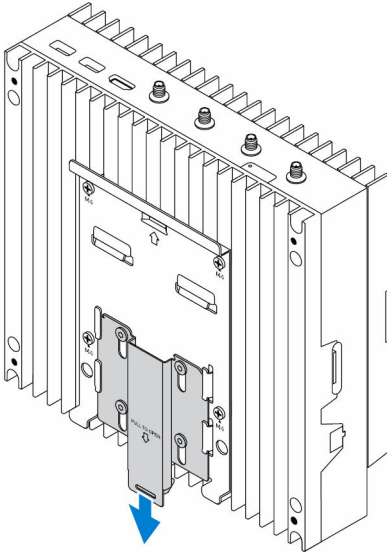

- 3** Mount the Dell Edge Gateway on a DIN rail.

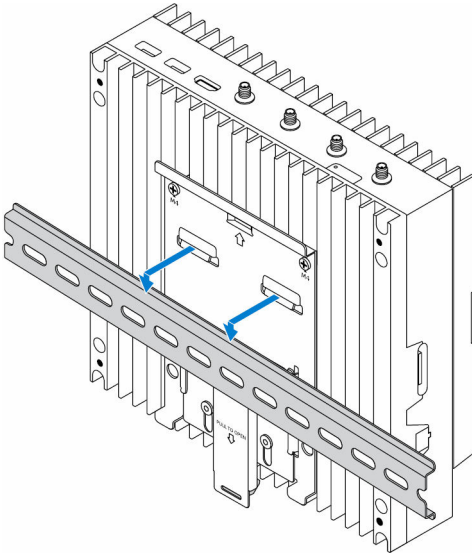

- 4 Secure the Dell Edge Gateway by pressing the latch.

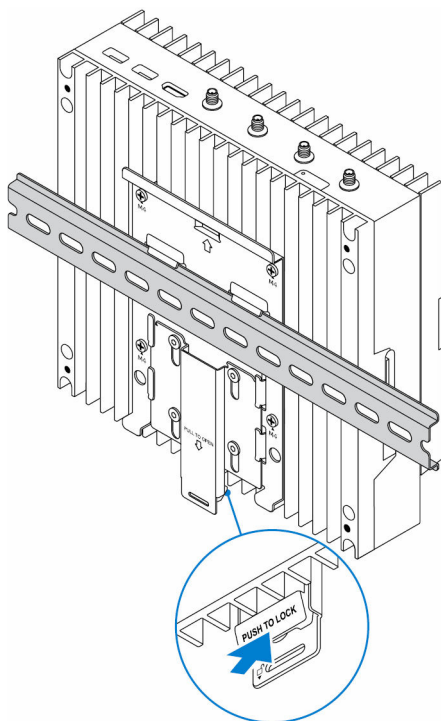

Inserting a micro-SIM card and activating your mobile broadband

△ CAUTION: It is recommended to insert the micro-SIM card before powering on the Dell Edge Gateway.

- 1 Shutdown your system.
- 2 Locate the micro-SIM card slot.
- 3 Using a paper clip or SIM eject tool eject the micro-SIM card tray.
- 4 Place the micro-SIM card on the tray.

△ CAUTION: Ensure that the micro-SIM card is aligned as shown in the image.

5 Close the micro-SIM card tray.

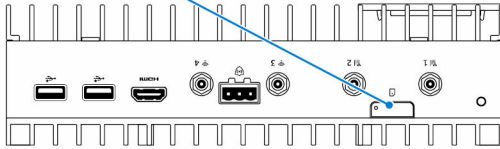
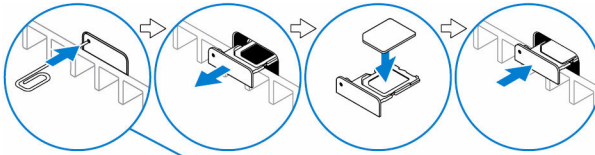

6 Power on your system.

7 Connect to Network



NOTE: To activate your mobile broadband service, please contact the service provider with the following information:

Windows OS

- a) Select the Network icon from the taskbar and then select **Cellular**.
The Cellular page displays.
- b) Select your **Mobile Broadband Carrier** to expand the options.
- c) Select **Advanced Options**.
The options are displayed.
- d) Make a note of the **International Mobile Equipment Identity (IMEI)** and the **Integrated Circuit Card Identifier (ICCID)**.

Ubuntu OS

Open the **Terminal** window.

- a) Go to super user mode by entering: `$sudo su -`
- b) Configure the Mobile Broadband connection profile:

```
#nmcli con add type gsm ifname ttyACM3 con-name  
<connection name> apn <apn> user <user name>  
password <password>
```
- c) Connect to the mobile network: `#nmcli con up <connection name>`

To disconnect from the mobile network: `#nmcli con down <connection name>`.

Wind River OS

- a) Configure the Mobile Broadband APN profile:

```
#uci set network.wwan.apn="<apn>"  
#uci commit network
```
- b) Connect to the mobile network: `#ifup wwan`

To disconnect from the mobile network: `#ifdown wwan`.

Removing the micro-SIM card



CAUTION: Removing the micro-SIM card while it is in use may cause data loss or result in application errors.

- 1 Using a paper clip or SIM eject tool eject the micro-SIM card tray.
- 2 Remove the micro-SIM card out of the micro-SIM card tray.

- 3 Replace the micro-SIM card tray into the system.

Setting up your operating system

Windows 10 Enterprise

 **NOTE:** For more information on setting up your Windows 10 Enterprise operating system, see www.dell.com/support/windows.

- 1 Power on the system.
The Windows configuration screen appears.
- 2 Setup the wireless connection for your system.
- 3 Create a local or Microsoft account.
The Windows 10 Enterprise setup is complete.

Ubuntu Snappy

 **NOTE:** For more information on setting up your Ubuntu Snappy operating system, see www.ubuntu.com/support.

- 1 Power on the system.
The Ubuntu Snappy configuration screen appears.
- 2 Setup the wireless connection for your system.
- 3 Enter your login and password.
The Ubuntu Snappy operating system is setup.

Wind River Linux

 **NOTE:** For more information on setting up your Wind River operating system, see <http://www.windriver.com/support>.

- 1 Power on the system.
The Wind River splash screen is displayed after the Dell Edge Gateway boots completes POST.
- 2 The operating system will take around twenty seconds to complete the loading process. Enter the login information.
- 3 Activate your Wind River operating system installation.
The Wind River operating system is setup.

Specifications

System information

Product Name	Dell Edge Gateway 5000/5100 (Industrial control equipment)
Processor	Intel Atom processor
Operating system	<ul style="list-style-type: none">• Windows 10• Ubuntu• Wind river Linux with Moon Island 3.0 stack
RAM	LPDDR3
Storage	<ul style="list-style-type: none">• 32 GB SSD• 64 GB SSD

Dimensions

Height	228.4 mm (8.99 inches)
Width	216 mm (8.50 inches)
Depth	<ul style="list-style-type: none">• Dell Edge Gateway 5000: 64.20 mm (2.52 inches)• Dell Edge Gateway 5100: 74.50 mm (2.93 inches)

Memory

Type	LPDDR3
Speed	1600 MHz
Configurations supported	2 GB, 4 GB, and 8 GB

Ports and connectors

Audio/video	One HDMI port
microSD card	One microSD-card slot

Ports and connectors

Network	<ul style="list-style-type: none">• Two RJ45 ports• Two Wi-Fi antenna ports• Two mobile broadband antenna ports• One CANbus port• One RS422/485 combo port• Two RS485 ports
USB	<ul style="list-style-type: none">• One USB 3.0 port• Two USB 2.0 ports

Communications

Wi-Fi	Dual-band 802.11b/g/n/ac
Bluetooth	Bluetooth 4.1 LE

Power requirements

Power terminal block connector input voltage/current	24 VAC (50-60Hz) or 24 VDC / 4A
Power adapter input voltage/current	19.5 VDC / 3.33A

Environmental requirements

Ingress Protection Rating	IP50
---------------------------	------

Temperature range:

Operating (with a maximum temperature gradation of 15°C (59°F) per hour)

- Dell Edge Gateway 5000: 0°C to 50°C (32°F to 122°F)
- Dell Edge Gateway 5100: -30°C to 70°C (32°F to 158°F)



NOTE: The maximum operating temperature is derated 1°C/305m (1000ft) above sea level altitude

Non-operating (with a maximum temperature

-40°C to 70°C (-40°F to 158 °F)

Environmental requirements

gradation of 15°C (59°F) per hour)

Relative humidity (maximum):

Operating (with maximum humidity gradation of 10% per hour) 10% to 90% (non-condensing)

Non-operating (with maximum humidity gradation of 10% per hour) 5% to 95% (non-condensing)

Altitude (maximum, unpressurized):

Operating -15.20 m to 5000 m (-50 ft to 16,404 ft)



NOTE: The maximum operating temperature is derated 1°C/305m (1000ft) above sea level altitude

Storage -15.20 m to 10,668 m (-50 ft to 35,000 ft)

I/O Module Overview

The I/O module allows you to install a PCIe x1 card and adds additional ports to your Dell Edge Gateway.

 **NOTE:** The power module is required to be installed with the Dell Edge Gateway to enable and use the I/O expansion module.

—

Features

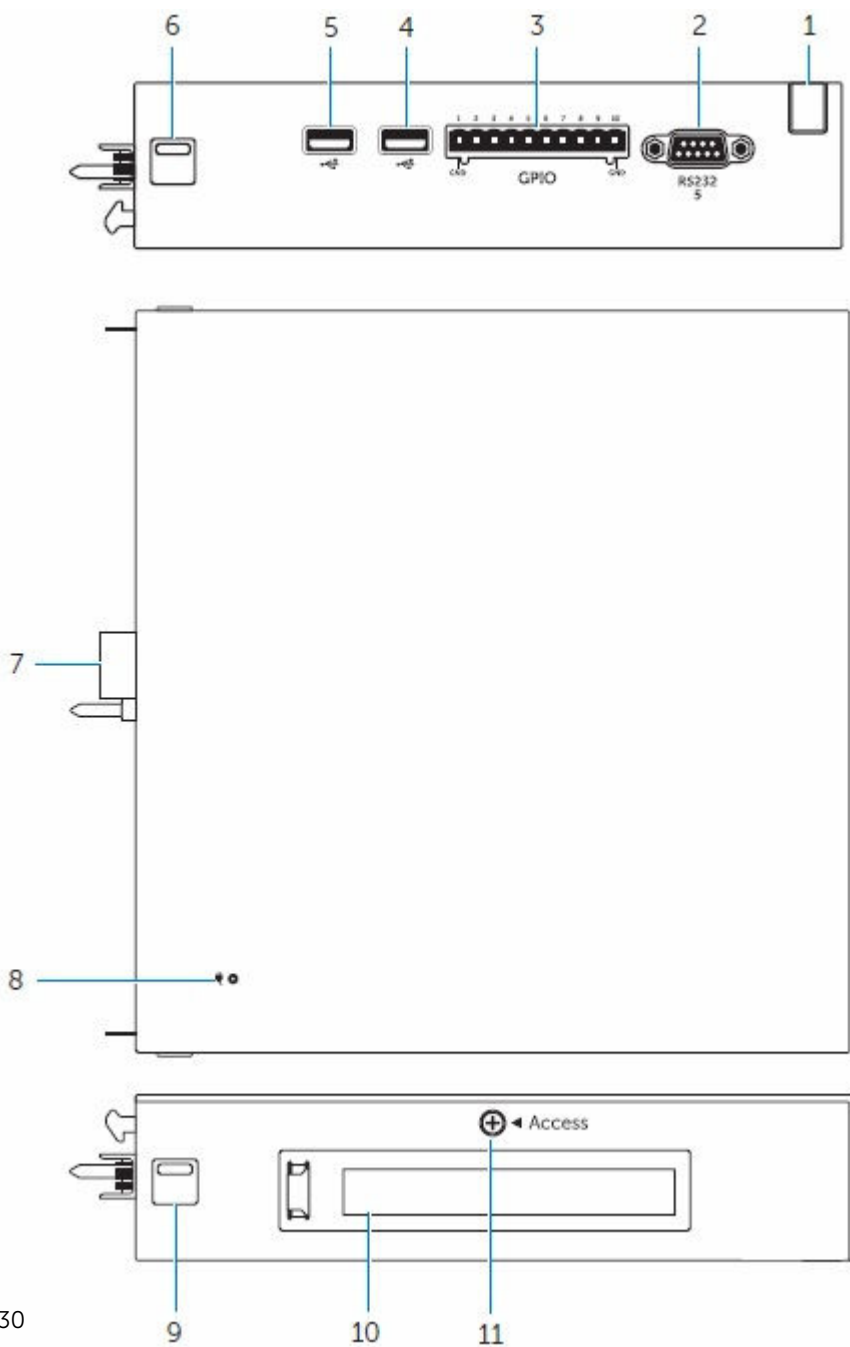

Feature	
1. Cable routing slot	Route any cable(s) that has to be connected to the PCI card installed in the I/O module.
2. RS232 port	Connect a RS2325 cable.
3. GPIO port	Connect a GPIO 8-pin cable.
4. USB 2.0 port	For USB 2,0 devices
5. USB 2.0 port	For USB 2,0 devices
6. Top release-latch	Push both the top and bottom release-latch to disconnect the power module from the Dell Edge Gateway.
7. I/O module expansion connector and guide pin	Connect the I/O module to the Dell Edge Gateway.
8. Power status light	Indicates the power state of the I/O module and the Dell Edge Gateway.
9. Bottom release-latch	Push both the top and bottom release-latch to disconnect the power module from the Dell Edge Gateway.
10. PCIe x1 card slot	Install PCIe x1 card on the I/O module.
11. I/O module cover removal screw	Remove the screw to open the box and install the PCIe card.

Setting up the I/O Module

 **CAUTION:** Before touching anything inside the system, ground yourself by touching an unpainted metal surface. While you work, periodically touch an unpainted metal surface to dissipate static electricity, which could harm internal components.

 **NOTE:** Install the PCIe expansion card in the I/O Expansion Module before mounting it on Wall mount or DIN rail.

- 1 Install the PCIe expansion card in the I/O Expansion Module - optional

- 2 Remove the dust cap and loosen the access cover screw that secures the I/O Expansion Module to the cover, slide in the direction shown and carefully lift it off the module.

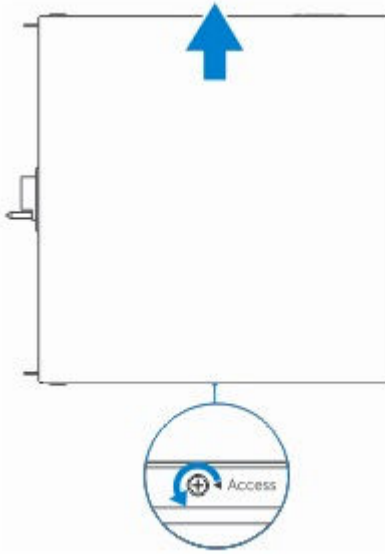

3

- 4 Install the PCIe card on the PCIe expansion card slot on the I/O Expansion Module.

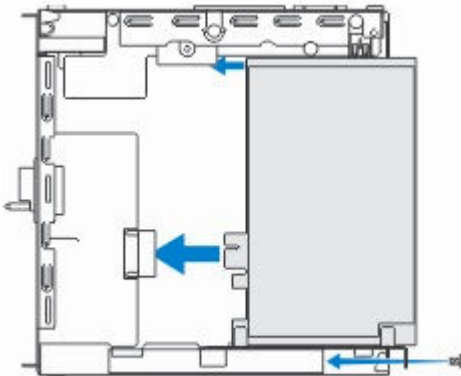

- 5 Replace the cover on the I/O Expansion Module.

 **NOTE:** Replace the dust-caps on any unused ports and connectors.

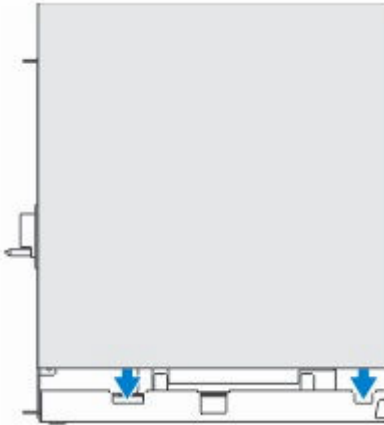

- 6 Tighten the screw that secures the cover to the I/O Expansion Module.

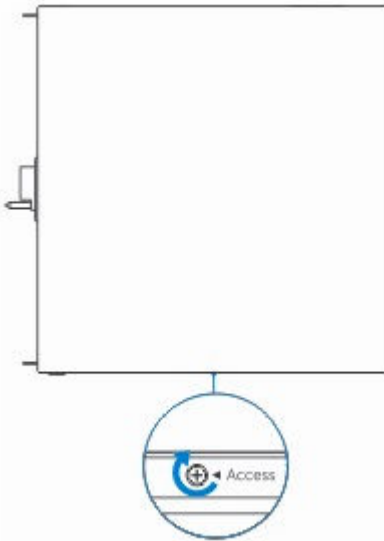

- 7 Remove the dust-cap covering the I/O Module expansion port on the Dell Gateway connector.

- 8 Align the I/O Module guide pin to port on the Dell Edge Gateway.

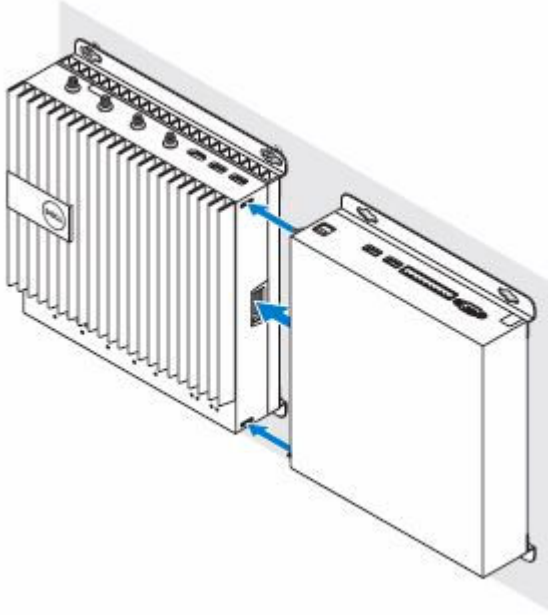

- 9 Slide the I/O Module until it is fully seated into the Dell Edge Gateway.



- 10 Lock the top and bottom latches to secure the module to the Dell Edge Gateway.

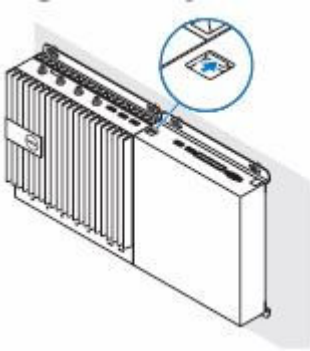

- 11 Install the Dell Edge Gateway and the I/O Module along with the Power Module at a desired location using wall-mount bracket or the DIN rail mount.

Wall Mount Bracket

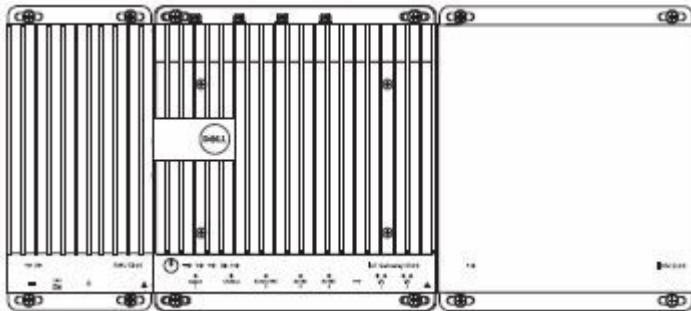

DIN Rail Mount

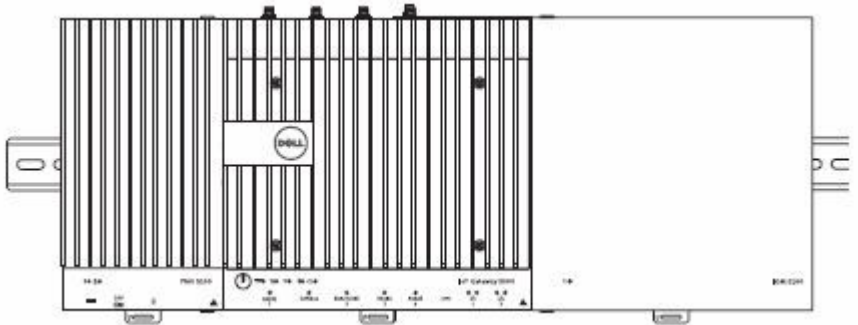

12 Connect to a power source and press the power button.

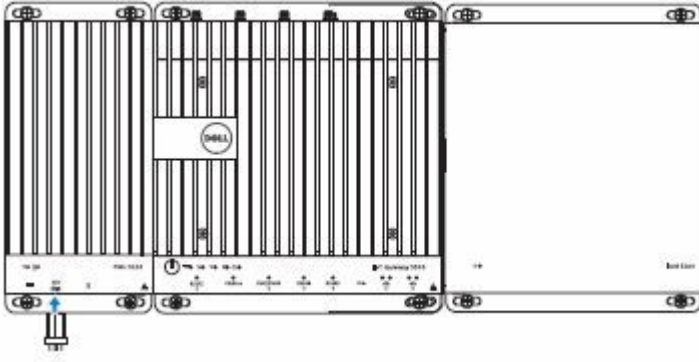

- NOTE: Connect a power cable to the +24V AC/DC or +19.5 VDC power adapter port on the Power Module.
- NOTE: The power adapter and sealed lead-acid battery is sold separately.
- NOTE: The power module is required to be installed with the Dell Edge Gateway to enable and use the I/O expansion module.

Specifications

Dimensions

Height	207.60 mm (8.17 inches)
Width	216 mm (8.50 inches)
Depth	47.70 mm (1.88 inches)

Ports and connectors

USB	Two USB 2.0 ports
I/O port	<ul style="list-style-type: none">• One RS232 port• GPIO 8-pin port

Power requirements

Phoenix connector input voltage/ current	24 VAC (50 Hz–60 Hz) or 24 VDC / 15A
Power adapter input voltage/current	19.5 VDC / 6.67A
Battery pack connector port	12 VDC / 15A

Environmental requirements

Ingress Protection Rating IP50



NOTE: Enclosure meets IP50 with the pre-installed PCIe blank bracket. System IP rating depends on the PCIe card IP rating.

Temperature range:

Operating (with a maximum temperature gradation of 15°C per hour)

-30°C to 70°C (-22°F to 158°F)



NOTE: The maximum operating temperature is derated 1°C/305m(1000ft) above sea level altitude.



NOTE: The enclosure meets this spec without a PCIe card. Operating temperature may change if a PCIe card is installed. Refer to the supported PCIe card section for more details.



NOTE: Any component to be assembled into the Expansion Module shall have a still air temperature rating that is equal to or higher than the PCIe card temperature rating. For without PCIe card cases, use system ambient + 3C to determine the inside air temperature.

Non-operating

-40°C to 70°C (-40°F to 158°F)

Environmental requirements

Relative humidity (maximum):

Operating (with maximum humidity gradation of 10% per hour) 10% to 90% (non-condensing)

Non-operating ((with maximum humidity gradation of 10% per hour) 5% to 95% (non-condensing)

Altitude (maximum, unpressurized):

Operating -15.2m to 5000m (-50ft to 16,404ft)



NOTE: The maximum operating temperature is derated 1°C/305m (1000ft) above sea level altitude.

Storage -15.20 m to 10,668 m (-50 ft to 35,000 ft)

Supported PCIe card power- PCIe card temperature and power rating must meet following table

System ambient after altitude derating (°C)	Maximum supported power dissipation (W) for 85° C or above still air rated PCIe cards	Maximum supported power dissipation (W) for 70° C still air rated PCIe cards	Maximum supported power dissipation (W) for 55°C still air rated PCIe cards
20	15	12	8
25	14	10	6
30	13	9	5
35	12	8	4
40	10	6	3
45	9	5	2
50	8	4	1
55	6	3	Not supported
60	5	2	Not supported
65	4	1	Not supported
70	3	Not supported	Not supported



NOTE: PCIe cards must support still air environment and must not require active cooling



NOTE: PCIe cards rated above 25W are not supported regardless of temperature rating



NOTE: If a PCIe card is rated at a temperature that has not shown in the table, use interpolation to calculate the maximum supported power.



NOTE: If a PCIe card is rated at a temperature greater than 85°C, it shall be treated as an 85°C rated card in determining the supported power.

Power Module Overview

The power module allows you to connect additional power sources to your Dell Edge Gateway. The power module allows you to connect to all three power sources, that is, the 24 AC/DC, 19.5 VDC, and a battery.



NOTE: The Power Module is required to be installed with the Dell Edge Gateway to enable and use the I/O expansion module.

Features

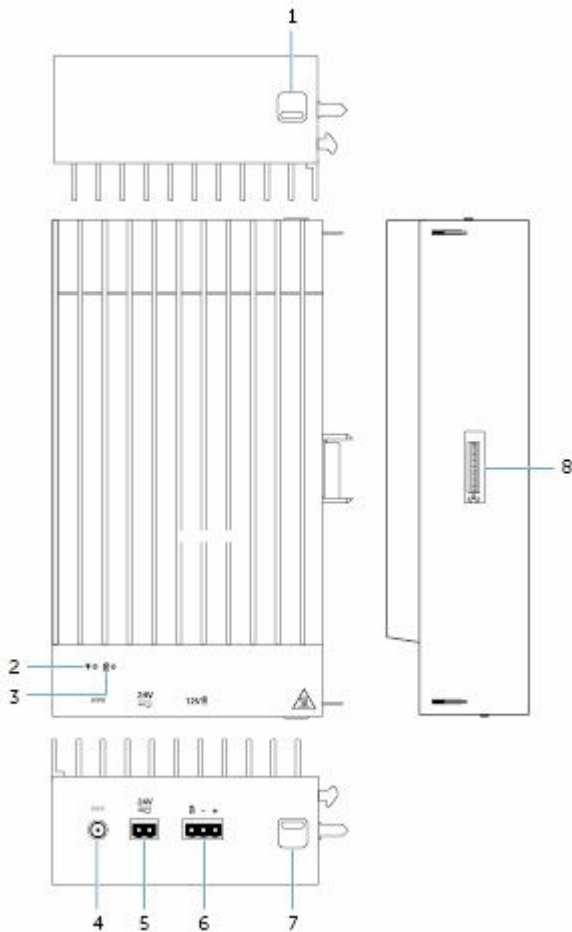

Feature

- | | |
|---|--|
| <ol style="list-style-type: none">1. Top release-latch
2. Power status LED | <p>Push both the top and bottom release-latch to disconnect the power module from the Dell Edge Gateway.</p> <p>Indicates the power-state of the power module and the Dell Edge Gateway.</p> |
|---|--|

Feature

- | | | |
|----|----------------------------------|--|
| 3. | Battery status LED | Indicates the power-state of the attached battery module. |
| 4. | 19.5 VDC power adapter port | Connect a +19.5 VDC power adapter connector to provide power to your system. |
| 5. | 24V AC/DC power port | Connect a +24V AC/DC power Phoenix connector to provide power to your system. |
| 6. | Sealed lead-acid battery port | Connect an external battery back to the power module. |
| 7. | Bottom release-latch | Push both the top and bottom release-latch to disconnect the power module from the Dell Edge Gateway. |
| 8. | Dell Edge Gateway expansion port | Connect the power module to the Dell Edge Gateway for increased power options and to power the I/O expansion module. |

Setting up the Power Module



WARNING: Before installing the Power Module shutdown the Dell Edge Gateway and disconnect the power cable.



NOTE: The power module is required to be connected with the Dell Edge Gateway to enable and use the I/O expansion module.

- 1 Remove the dust-cap covering the Power Module expansion port on the Dell Gateway connector.

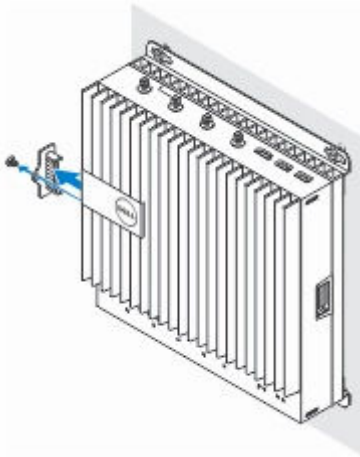

- 2 Align the Power Module guide pins to the power module port on the Dell Edge Gateway and slide the Power Module until it is fully seated in the Dell Edge Gateway

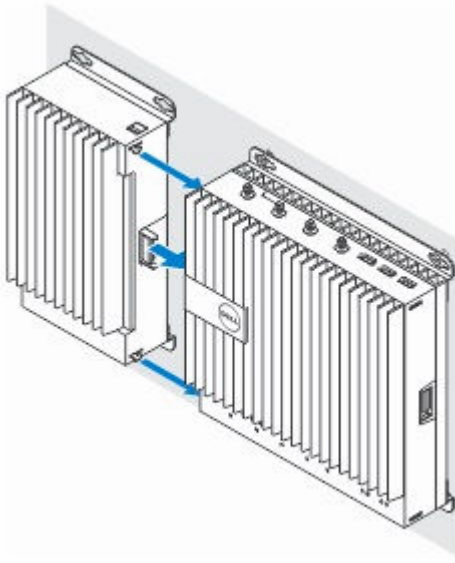

- 3 Ensure the top and bottom latches are locked to secure the module to the Dell Edge Gateway

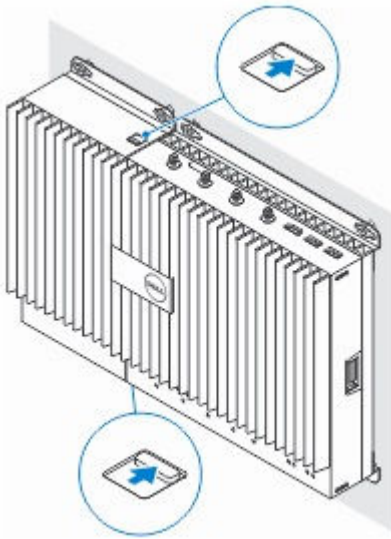

- 4 Install the Dell Edge Gateway and the Power Module at a desired location using wall-mount bracket or the DIN rail mount.

Wall-mount bracket

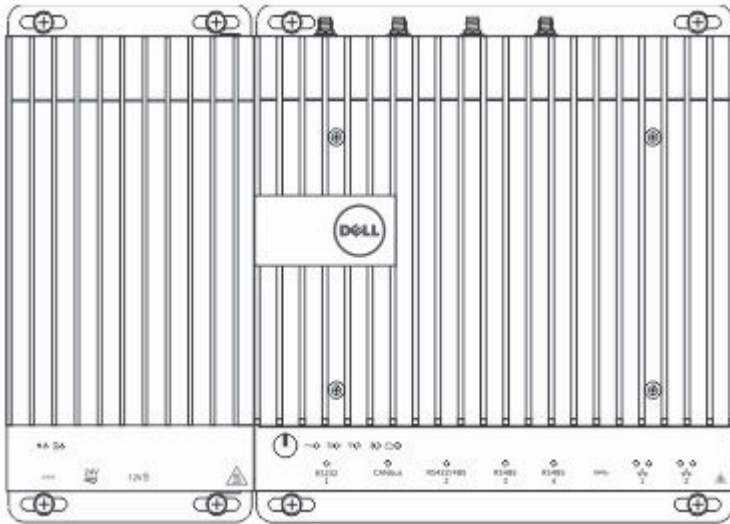

DIN rail

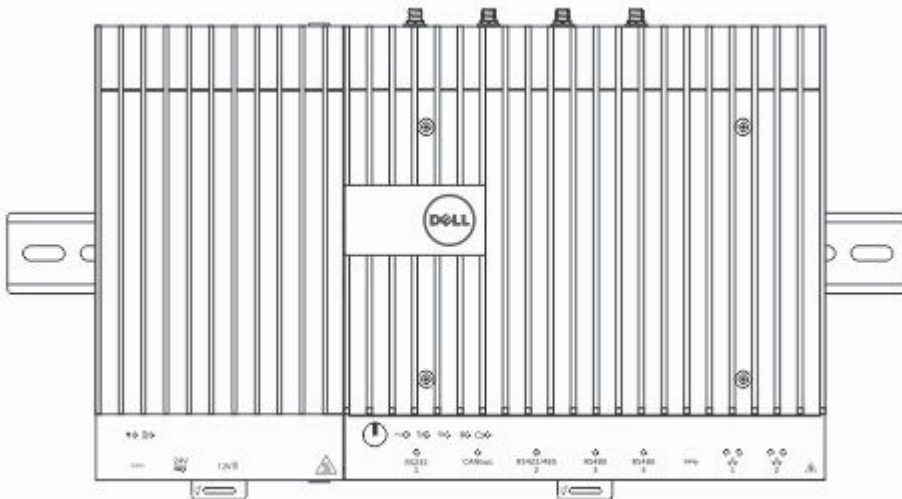

- 5 Connect the power sources and press the power button on the Dell Edge Gateway.

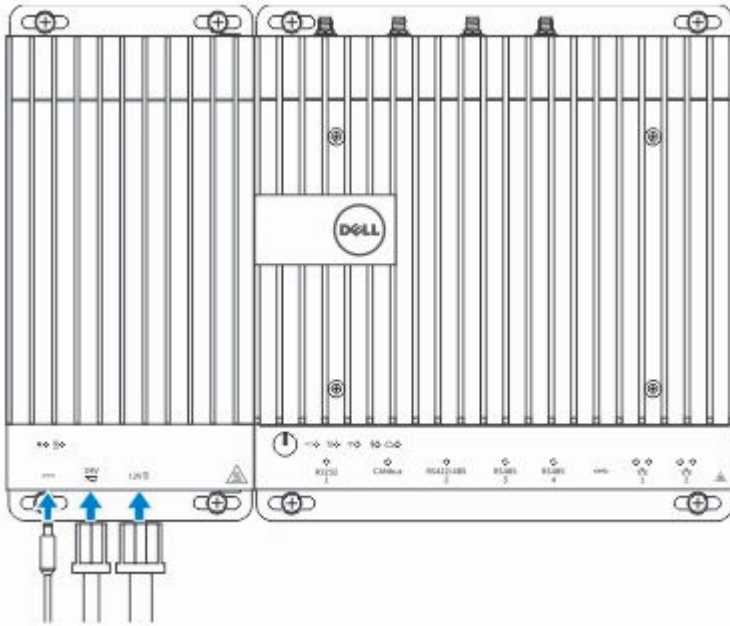

- NOTE: You can connect the power cable to the 24V AC/DC, 19 VDC, and a battery simultaneously.
- NOTE: The power adapter and sealed lead-acid battery are sold separately.
- NOTE: Installing the battery is optional. It is recommended to connect a sealed 12V lead-acid battery to the power module.
- NOTE: The 12V lead-acid battery is not sold by Dell.

Power module — Connecting a battery

For uninterrupted operation of the system, an additional redundancy option is to connect an external battery. If the power supply through the power adapter (19.5 VDC) or power port (24 VAC or 24 VDC) fails, the power module will seamlessly switch to the battery pack.

 **WARNING:** Make sure the battery is installed in a secure location and follows all local fire codes and regulation. Read the safety instructions that is shipped with the battery.

 **WARNING:** Only a trained technician should setup/replace the battery.

 **WARNING:** Only install the battery inside an enclosure that meets fire safety requirements.

 **WARNING:** Only Sealed Lead Acid (SLA) battery rated 50Ah (or less) should be used

 **WARNING:** Before installing that all of three power inputs (Terminal Block/Power Jack/Battery Input) in power module shall be protected by the 20 A fuses or circuit-breakers(over current protection device) in front of this system.

Wiring Design Procedure

 **NOTE:** It is recommended that the cable connecting the system to the battery be able to carry 15 A of current as per the AWG standards.

 **NOTE:** It is recommended to include a 15 A breaker/fuse to the battery setup as per the AWG standards.

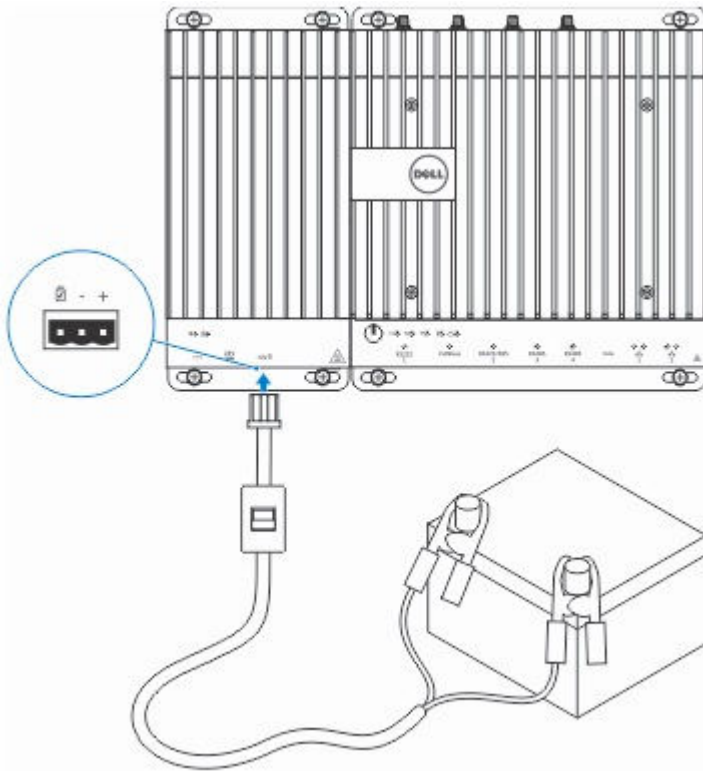

- Calculate the total length of wire from the battery to the system.
- Determine current-carrying capacity in the wire.
- Determine correct wire gauge in the intersection of amps and feet.

Specifications

Power requirements

Terminal block connector input voltage/current	24 VAC (50 Hz–60 Hz) or 24 VDC / 15A
Power adapter input voltage/current	19.5 VDC / 6.67A
Battery pack connector port	12VDC / 15A

Environmental requirements

Ingress Protection Rating IP50

Temperature range:

Operating (with a maximum temperature gradation of 15°C per hour) -30°C to 70°C (-22°F to 158°F)

 **NOTE:** The maximum operating temperature is derated 1°C/305m(1000ft) above sea level altitude.

Non-operating -40°C to 70 °C (-40°F to 158°F)

Relative humidity (maximum):

Operating (with maximum humidity gradation of 10% per hour) 10% to 90% (non-condensing)

Non-operating ((with maximum humidity gradation of 10% per hour) 5% to 95% (non-condensing)

Altitude (maximum, unpressurized):

Operating -15.2m to 5000m (-50ft to 16,404ft)

 **NOTE:** The maximum operating temperature is derated 1°C/305m (1000ft) above sea level altitude.

Storage -15.20 m to 10,668 m (-50 ft to 35,000 ft)

Enclosure Overview

The rugged enclosure allows you to install the Dell Edge Gateway in harsh environment, like locations that are subjected to high temperature variation, dust particle, and humidity.

Features

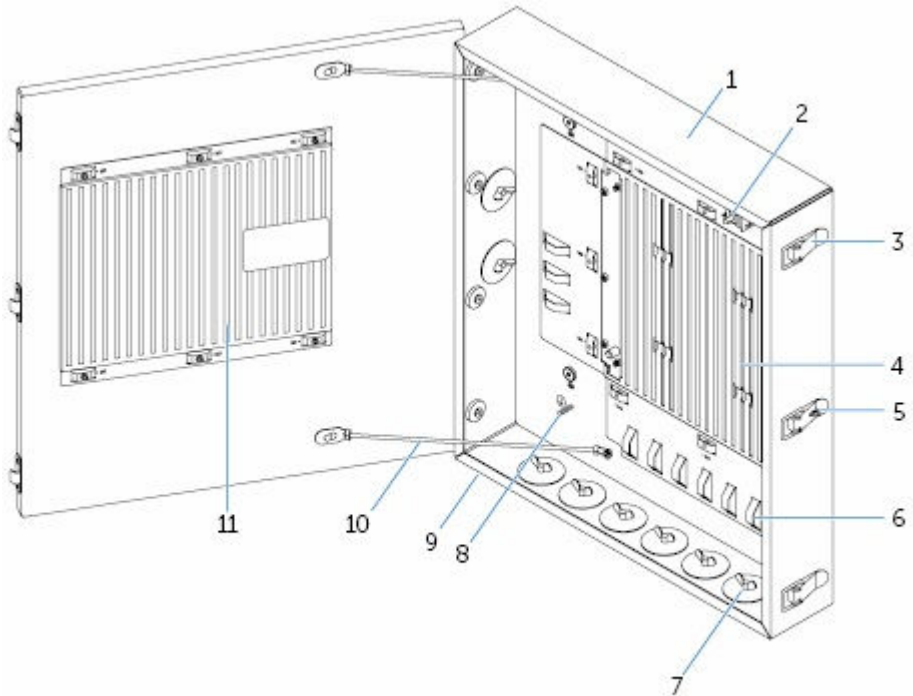

Feature

- | | |
|-------------------------------|---|
| 1. Rugged Enclosure | install the Dell Edge Gateway in the rugged enclosure when using in harsh environments condition. |
| 2. intrusion detection switch | detects unauthorized system access |

Feature

- | | | |
|-----|----------------------------|--|
| 3. | door securing latch (3) | secure the enclosure |
| 4. | thermal ribs | dissipates the heat generated by the system |
| 5. | latch lock-out | secure the system with a pad lock |
| 6. | cable tie-off (17) | to prevent accidental cable disconnection, tie all cables to the cable tie-off guides. |
| 7. | cable conduit openings (8) | route the cables through the conduits (1 inch and .75 inch diameter) |
| 8. | primary ground (internal) | connect the grounding cable to the system |
| 9. | primary ground (external) | connect the grounding cable to the system |
| 10. | door-stop cables (2) | restricts the door from opening |
| 11. | door thermal ribs | dissipates the heat generated by the system |

Setting up the Enclosure

- 1 Install the Enclosure's wall mount bracket at a desired location and secure it to the wall using the wall mount screws.

 **NOTE:** Ensure the notch on the bracket is on the top.

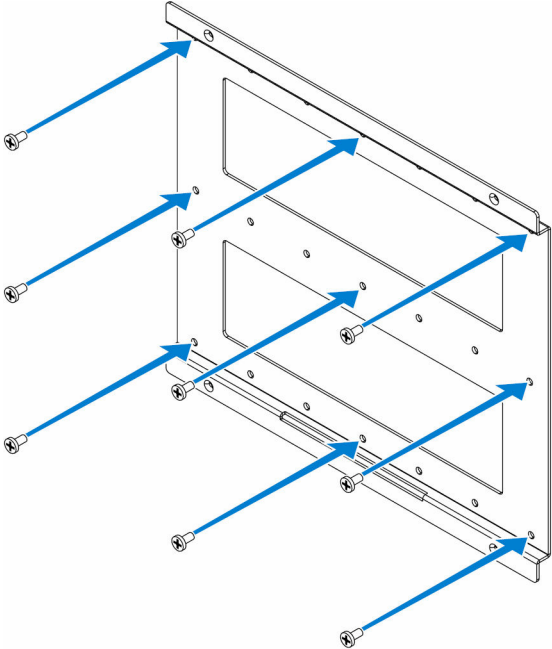

- 2 Open the Enclosure.

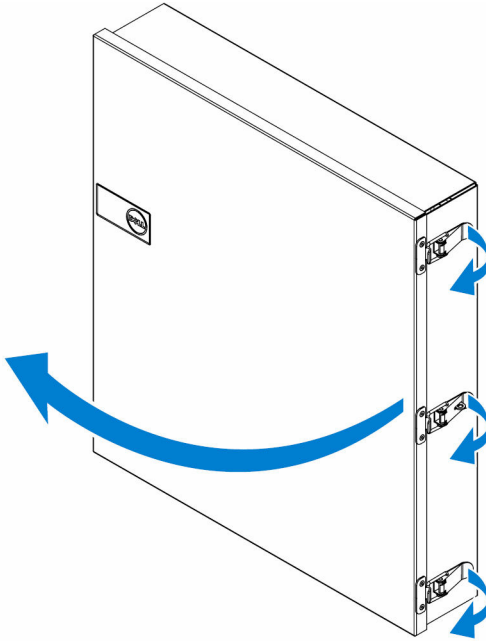

- 3 Place the Enclosure on the wall mount bracket and align the tab on the Enclosure to fit into the notch on the wall bracket.

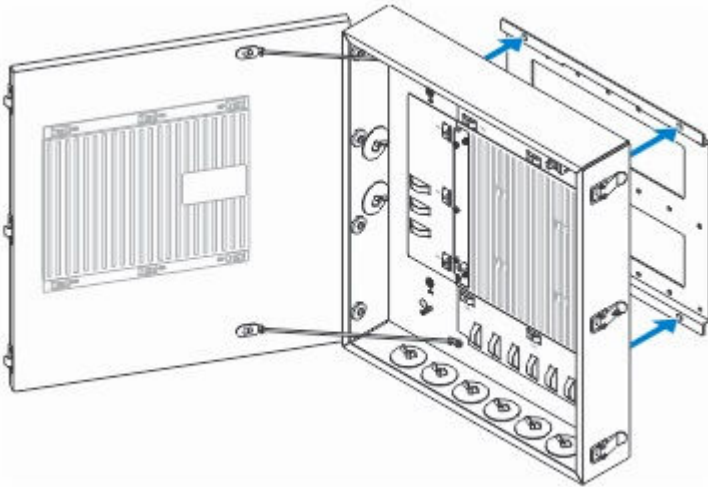

- 4 Place and tighten the screws with rubber washers to secure the Enclosure to the wall brackets.

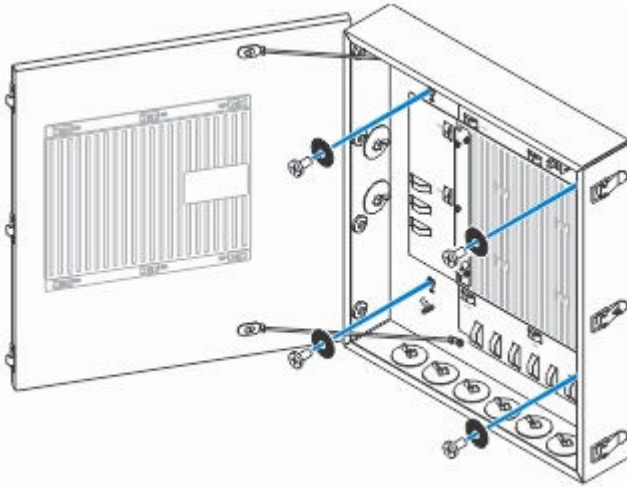

- 5 Align the screw holes on the wall mount brackets with the screw holes on the Dell Edge Gateway, place and tighten the screws to secure the wall mount brackets to the system.

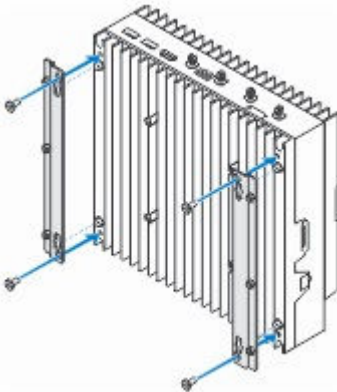

- Align the screw holes on the Dell Edge Gateway's wall mount brackets with the screw holes on the Enclosure by positioning the system onto the Enclosure's two locator pins, place and tighten the screws to secure the system to the enclosure

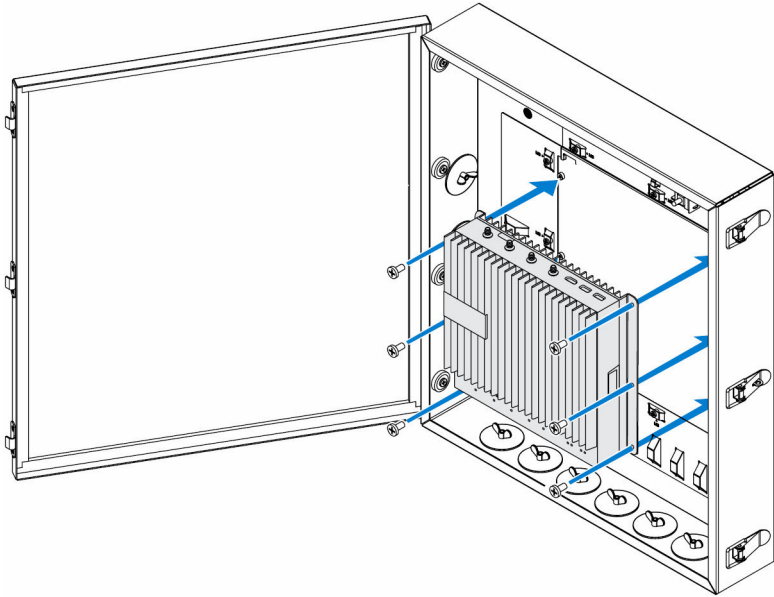

- 7 Connect the intrusion switch to the system.

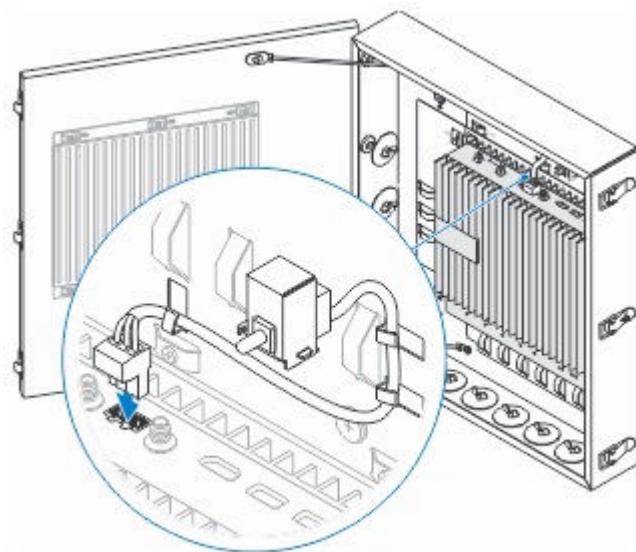

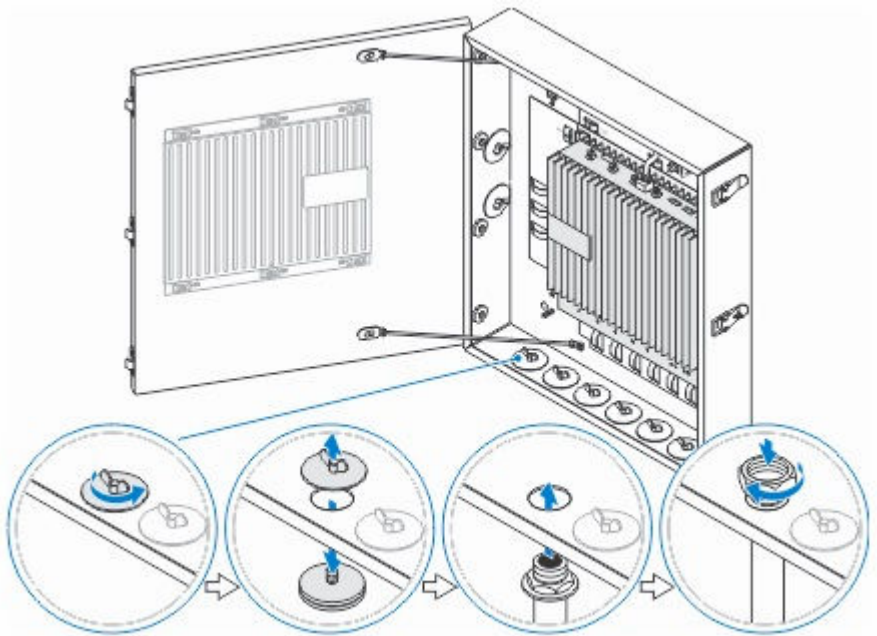

- 8 Remove the desired conduits opening plugs on the bottom or the left side of the enclosure and install the wiring conduits.

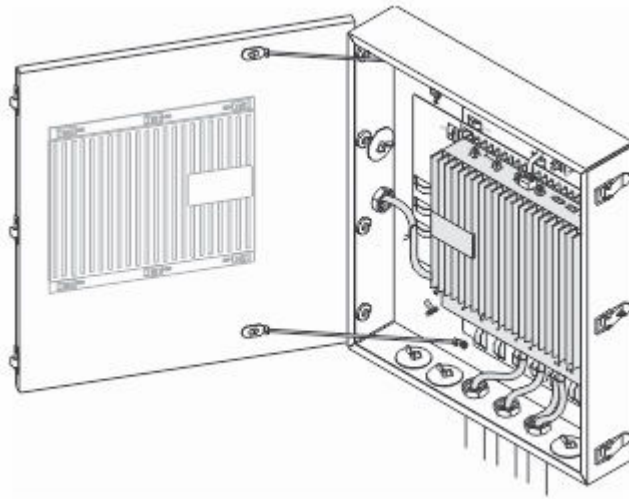

NOTE: To ensure that dust and water does not enter the enclosure install a conduit rated as IP65.

- 9 Route your cables through the cable conduits on the bottom or the left side of the enclosure.



 **NOTE:** To reduce the risk of accidental cable disconnection, tie all cables to the cable tie-off guides.

10 Close and securely latch the Enclosure door.

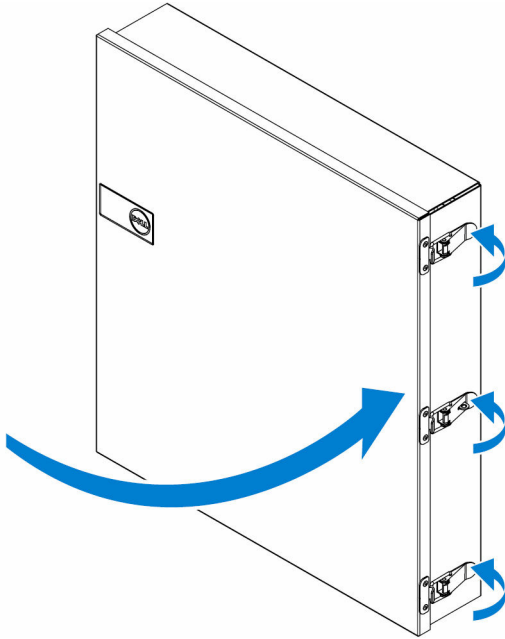

Specifications

Dimensions

Height	397 mm (15.62 inches)
Width	443.40 mm (17.46 inches)
Depth	79.80 mm (3.14 inches)

 **NOTE:** The dimensions do not include the latches and wall bracket on back of enclosure; the wall bracket adds 5 mm to the depth.

Environmental requirements

Ingress Protection Rating IP65

 **NOTE:** Require IP65 or above conduit connection.

Temperature range:

Environmental requirements

Operating (with a maximum temperature gradation of 15°C (59°F) per hour)

- Dell Edge Gateway 5000: 0°C to 45°C (32°F to 113°F)
- Dell Edge Gateway 5100: -30°C to 70°C (-22°F to 158°F)

 **NOTE:** The maximum operating temperature is derated 1°C/305m (1000ft) above sea level altitude.

 **NOTE:** The maximum operating temperature is derated 18°C (32.4°F) under direct solar thermal load.

Non-operating (with a maximum temperature gradation of 15°C (59°F) per hour)

-40°C to 70°C (-40°F to 158 °F)

Relative humidity (maximum):

Operating (with maximum humidity gradation of 10% per hour)

10% to 90% (non-condensing)

Non-operating (with maximum humidity gradation of 10% per hour)

5% to 95% (non-condensing)

Altitude (maximum, unpressurized):

Operating

-15.2m to 5000m (-50ft to 16,404ft)

 **NOTE:** The maximum operating temperature is derated 1°C/305m (1000ft) above sea level altitude.

Storage

-15.2m to 10,668m (-50ft to 35,000ft)

Setting up the ZigBee Dongle

CAUTION: Do not connect the ZigBee dongle if the Dell Edge Gateway is installed inside the Rugged Enclosure.

NOTE: Do not connect the ZigBee dongle to the internal USB port of the I/O expansion module.

- 1 Shut down your Dell Edge Gateway.
- 2 Connect the ZigBee dongle to any external USB port on your Dell Edge Gateway.

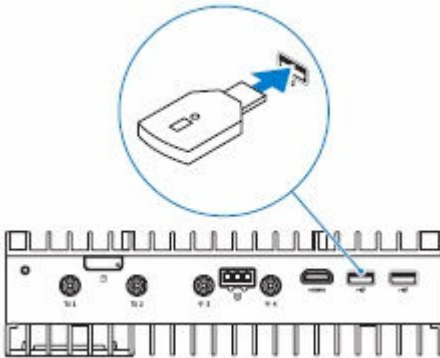

or

Connect the ZigBee dongle to any external USB port on the I/O module.

NOTE: Do not connect the ZigBee dongle to the internal USB port of the I/O expansion module.

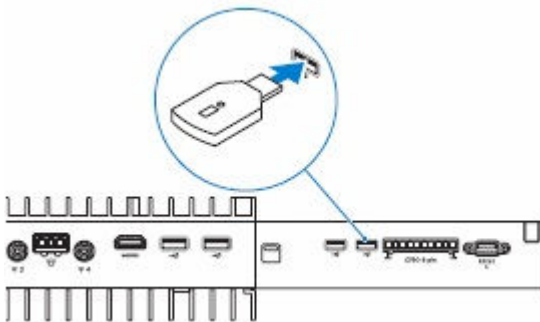

3 Turn on the Dell Edge Gateway and complete setup.



NOTE: For ZigBee development information go to SiLabs developer website at www.silabs.com/ or contact the system's application provider.

Contacting Dell

To contact Dell for sales, technical assistance, or customer service issues:

- 1 Go to **www.dell.com/contactdell**.
- 2 Verify your country or region in the **Choose a Country/Region** drop-down list at the bottom of the page.
- 3 Select the appropriate service or support link based on your requirement or choose the method of contacting Dell that is convenient for you.

Dell provides several online and telephone-based support and service options. Availability varies by country and product, and some services may not be available in your area.



NOTE: If you do not have an active internet connection, you can find contact information on your purchase invoice, packing slip, bill, or Dell product catalog.